

Rev. B

O-CE1-0SXXYY-X-E-X-5.000 MHz
Precision Ultra Low Phase Noise OCXO in 36x27 mm
“Europack”

Product Data Sheet

Features

- SC-cut crystal
- High Stability
- Low Aging
- Ultra Low Phase Noise
 Extraordinary (E) -93 dBc/Hz at 0.1 Hz
 -128 dBc/Hz at 1 Hz
 -152 dBc/Hz at 10 Hz
 -175 dBc/Hz on the floor
- Sine Wave output +14 dBm TYP

Applications

- Instrumentation
- GPS
- Telecommunication Systems
- Radar
- COTS/Dual use

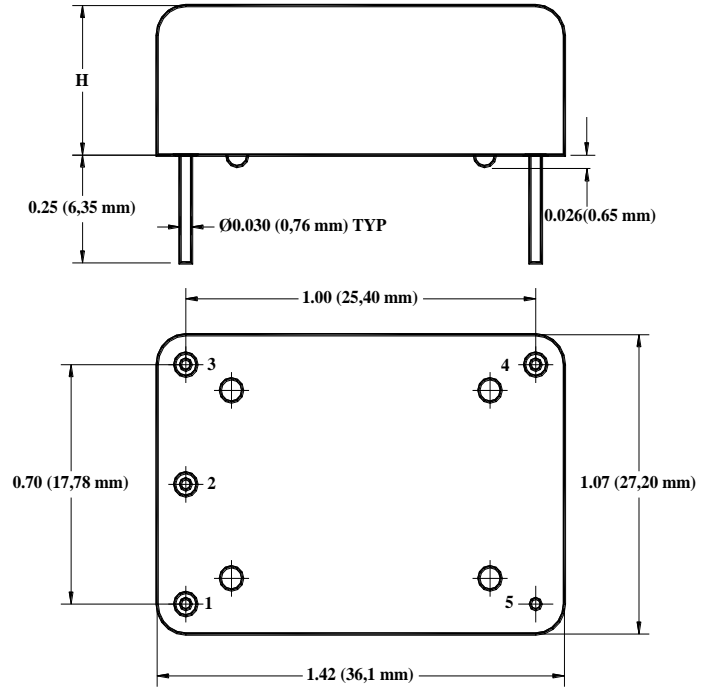

H code	Height, inches (mm) TYP
5	0.5 (12.7 mm)
6	0.63 (16 mm)
7	0.75 (19 mm)
1	1.0 (25.4 mm)



Rev. A

Parameter	Symb	Condition	Min	Typ	Max	Unit	Note
-----------	------	-----------	-----	-----	-----	------	------

Absolute Maximum Ratings

Input Break Down Voltage	Vcc	5 V supply	-0.5		5.5	V	
Storage temper.	Ts		-50		90	°C	
Control Voltage	Vc		-1		11	V	Slope option "L"

Electrical (6)

Frequency	F			5.000		MHz	
Frequency stability	$\Delta F/F$	vs. Temp.	From ± 2.0			ppb	See chart below
		vs. Supply		0.1	0.2	ppb/5% Vcc	
		vs. Load			0.5	ppb/5% load var.	
Aging		per day per year, first year second year 10 years		2E-10 2E-8 1E-8 1E-7			after 30 days
Allan Deviation		0.1 s		2E-13	3E-13		Static and benign conditions
		1 s		4E-13	5E-13		
		10 s		2E-12	4E-12		
		100 s		5E-12	7E-12		
SSB Phase Noise (achieved after 10 minutes warm-up)		0.1 Hz		-93		dBc/Hz	Static and benign conditions. Test schedule TBD
		1 Hz		-128			
		10 Hz		-153			
		100 Hz		-162			
		1 KHz		-172			
		10 KHz		-174			
		100 KHz		-175			
Retrace		After 30 minutes			± 2	ppb	24 Hours off 1*
G-sensitivity		Gamma 3 directions			± 1.0	ppb/G	
Input Voltage	Vcc		4.75	5.0	5.25	V	
Power consumption, Still air	P	steady state, 25°C		1.6	1.8	W	Still air
		start-up @ -30°C		4.0	4.5		
Spectral Purity		Subharmonics		none		dBc	Produced by device, not set-up related
		Spurious			-135		
		Harmonics		-35	-30		
Load	AC-coupled 50 Ohm (Sine-wave)						
Warm-up time	τ	to 0.1ppm accuracy		3	5	minutes	
Output Waveform	Sine-wave						
Output Power			+13	+14	+15	dBm	
Control voltage	Vc		0		10.0	V	L slope
Input impedance	Zin	At Vc pin	10			KOhm	L slope
Modulation bandwidth	Fm		DC		1	KHz	L slope
Reference Voltage	Vref			4.5		V	
Output Impedance		At Vref pin		100		Ohm	
Pull range		from nominal F	± 0.3	± 0.4		ppm	L slope
Deviation slope		Monotonic, positive		0.12		ppm/V	L slope
Setability	Vc0	@25°C, Fnom.		4.5 \pm 0.5		V	L slope
Initial calibration	$\Delta F/F$	Vc = 4.5 V			± 70	ppb	Internally biased 3*,1*,4*



FREQUENCY CONTROLS, INC.

Rev. B

Notes

- 1*. Longer storage time, especially at low temperatures, may affect both retrace and setability parameters. It may require few days on power for re-stabilization.
- 2*. All parameters, unless otherwise specified, are guaranteed over specified temperature and Vcc range. The tests of phase noise and short-term stability, however, are performed at room temperature in benign and static environment only.
- 3*. It is highly recommended, if possible, to avoid tuning the calibration externally in order to avoid deteriorating the phase noise and short-term stability performance. If necessary, metal film low noise resistors with bias from Vref port must be used.
- 4*. If No Vc option is selected, pin #1 is not connected. Initial calibration in this case will be ± 50 ppb MAX, ±25 ppb TYP as shipped.
- 5*. Frequency jumps < 300E-12 (1 s gate time on the counter) guaranteed, not tested.

Environmental and Mechanical

Operating temp. range	0°C to 70°C Standard, Other options – see chart below
Storage Temperature	-50°C to 90°C
Mechanical Shock	Per MIL-STD-202, 30G, 11ms
Vibration	Per MIL-STD-202, 5G to 2000 Hz
Soldering Conditions	260°C for 10s Max leads only

Electrical Connections

Pin Out	Pin #1-Vc or N/C ; Pin#2 – Vref ; Pin #3 – Vcc; Pin #4- Output ; Pin #5- GND;
----------------	---



Rev. B

Creating a Part Number

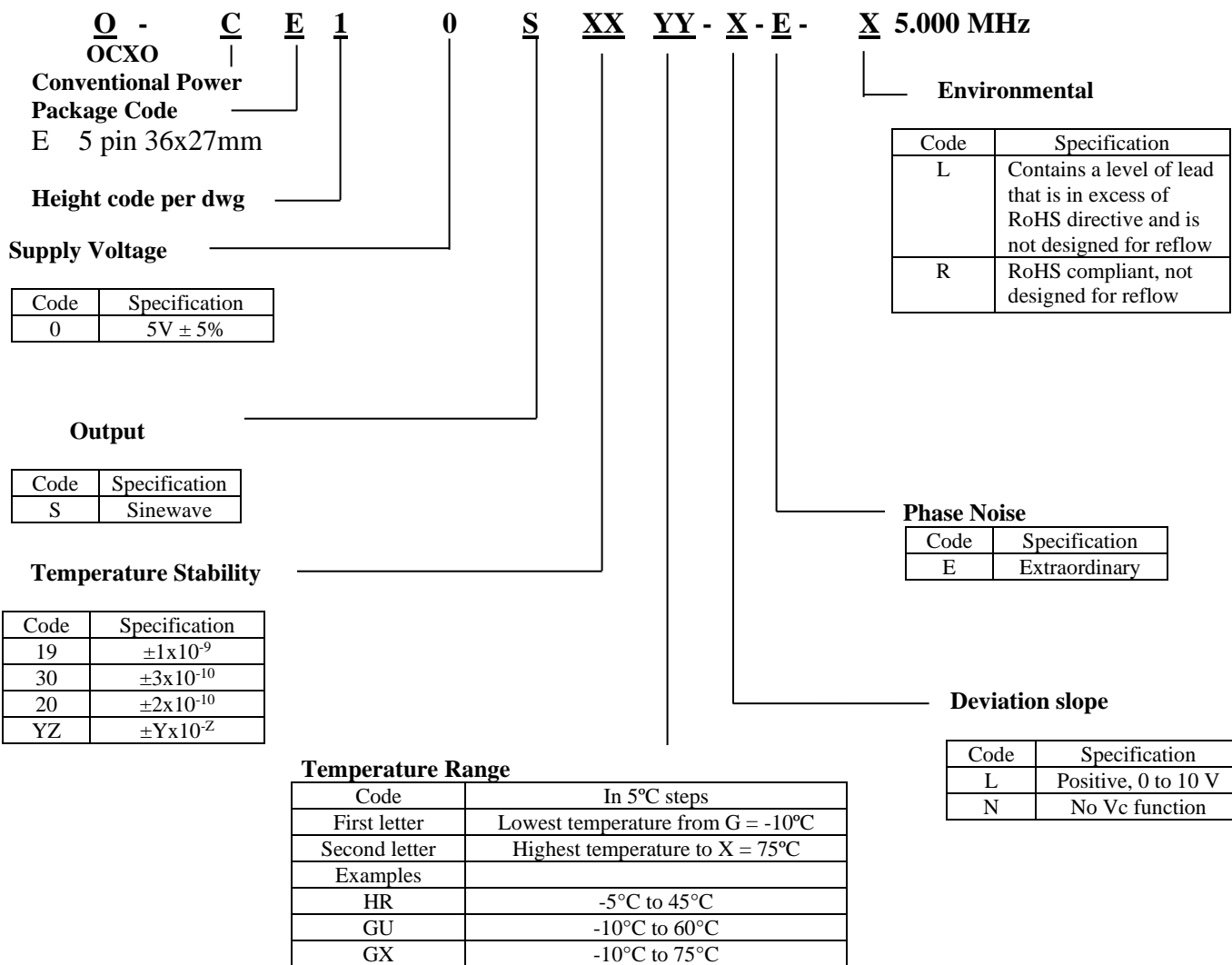

7*Temperature Code Table

Letter	Temp °C	Letter	Temp °C	Letter	Temp °C	Letter	Temp °C	Letter	Temp °C	Letter	Temp °C
A	-40	F	-15	K	10	P	35	U	60	Z	85
B	-35	G	-10	L	15	Q	40	V	65		
C	-30	H	-5	M	20	R	45	W	70		
D	-25	I	0	N	25	S	50	X	75		
E	-20	J	5	O	30	T	55	Y	80		



FREQUENCY CONTROLS, INC.